

# U-Bend Coil

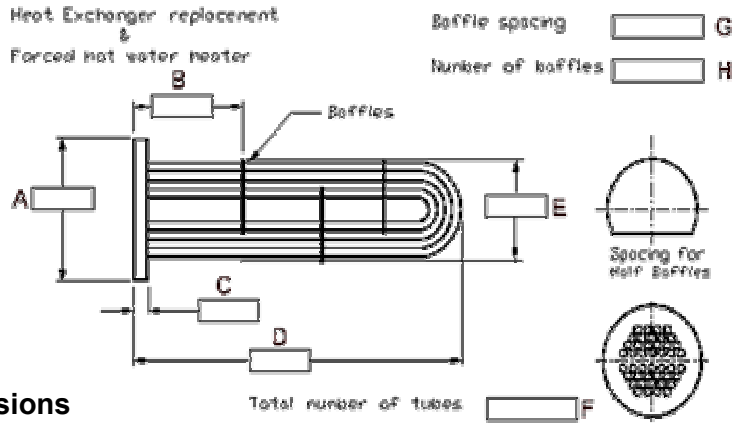

## Enter the Coil Dimensions

A.  B.  C.  D.  E.  F.  G.  H.

## Tube Sheet Material

- Copper Lined  Steel  Brass  Other

## Wall

- Single  Double

## Tubing Material

- Copper  90:10 Cupro-Nickel  316 Stainless Steel  304 Stainless Steel  Brass

## Tubing Overall Diameter

- 3/4"  1/2"  5/8"  Other

## Tubing Gauge (Thickness)

- 20 BWG (0.035")  19 BWG (0.042")  18 BWG (0.049")  16 BWG (0.065")

## Tube Spacer Type

- Baffle  Spacer

## Tube Baffle/Spacer Material and Thickness

Copper 0.050"  
Copper 0.125"  
Steel 0.0196"  
Steel 0.0897  
90:10 Cupro-Nickel 0.093  
316 Stainless Steel, 0.0598"  
316 Stainless Steel, 0.0125  
Teflon 0.25"

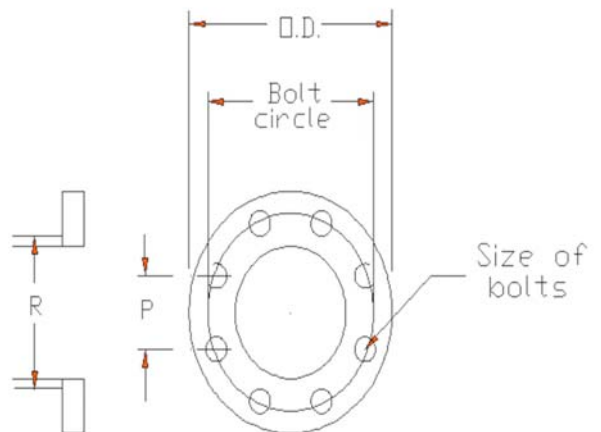

**Tube Baffle/Spacer Orientation**

- Horizontal     Vertical

**\*Please enter the information and fax to (770) 507-4904  
So we may process your request.**

**Number of Passes**

- 2     4     6

**Tube Sheet Style**

- Between the Bolts     Full Faced     Full Faced Drilled and Tapped

- Tube Pitch**     Square     Triangular

- P- Center to center bolt holes
- Q- Number of Bolts
- R- O.D. or circumference of neck
- S- Length of unit
- T- O.D. of tube sheet
- U- Bolt Circle
- V- Size of Bolts